



TARA ELECTRIC VEHICLES INC

taraelectricvehicles.com
626-500-9956 info@taraelectricvehicles.com
TARA SERIES PERSONAL BROCHURE V3.20 Apr 30, 2025



TARA ELECTRIC VEHICLES

TARA SERIES

Personal



All Rights Reserved By Tara Electric Vehicles.

A REVOLUTION IN THE GOLF CART INDUSTRY

TARA was born to push boundaries and reimagine what personal and golf mobility could be. Backed by two decades of industry expertise, we have created vehicles that empower users to explore freely, confidently, and with unmistakable style.

TARA stands as a symbol of bold design, intelligent engineering, and forward-thinking innovation. Designed for both golf courses and personal use, TARA breaks conventions and redefines expectations—encouraging you to go further, to see more, and to experience every journey in a new light.



- 6 FACTORIES
- 8 PRODUCT LINES
- 500,000 CARTS SOLD

20 YEARS
EXPERIENCE
IN THE GOLF CART
INDUSTRY

ROADSTER 2

LED HEADLIGHTS
AND
TAILLIGHTS

ILLUMINATED
SPEAKERS &
SOUND BAR

4-WHEEL
HYDRAULIC
BRAKES



DESIGNED FOR
GOLFING



ROOF
DRAINAGE



14" ALUMINUM WHEEL
215/45R14 RADIAL TIRE



ADJUSTABLE
STEERING COLUMN

MULTI-FUNCTIONAL DASHBOARD

COMFORT GRIP STEERING WHEEL

Featuring a central scoreboard clip for easy score tracking.

CONTROL SWITCHES

- Durable ignition switch key design.
- Direction selection knob for smooth transitions between gears.

HANDY, TANGIBLE, EASY ACCESS



LED HEADLIGHTS
AND
TAILLIGHTS

ILLUMINATED
SPEAKERS &
SOUND BAR

4-WHEEL
HYDRAULIC
BRAKES

ROADSTER 2+2

MULTI-FUNCTIONAL DASHBOARD

ADJUSTABLE STEERING COLUMN

Designed to enhance driving ease, it offers better control over the driving view and adjustable distance between the driver and the steering wheel.

CONTROL SWITCHES

- Durable ignition switch key design.
- Direction selection knob for smooth transitions between gears.

HANDY, TANGIBLE, EASY ACCESS



REAR ARMRES WITH BUILT-IN STORAGE COMPARTMENT



UNDER SEAT CONCEALED STORAGE COMPARTMENT



FLIP-FLOP REAR SEAT WITH STORAGE & REAR ARMREST



14" ALUMINUM WHEEL
215/45R14 RADIAL TIRE

EXPLORER 2+2

LED HEADLIGHTS
AND
TAILLIGHTS

ILLUMINATED
SPEAKERS &
SOUND BAR

4-WHEEL
HYDRAULIC
BRAKES



REAR ARMREST WITH BUILT-IN
STORAGE COMPARTMENT

REAR HANDRAIL WITH FOOTREST



14" ALUMINUM WHEEL/
23X10-14 SILENT TIRE WITH
OFF-ROAD THREAD



ADJUSTABLE
STEERING COLUMN

MULTI-FUNCTIONAL DASHBOARD

ADJUSTABLE STEERING COLUMN

Designed to enhance driving ease, it offers better control over the driving view and adjustable distance between the driver and the steering wheel.

CONTROL SWITCHES

- Durable ignition switch key design.
- Direction selection knob for smooth transitions between gears.

HANDY, TANGIBLE, EASY ACCESS



RUNNING BOARD



REAR STEPS



HEAVY-DUTY
BRUSH GUARD



ALUMINUM CHASSIS

Tara features an ultra-strong and lightweight chassis, complemented by a lightweight lithium battery pack. This combination offers a light and nimble driving experience, allowing it to glide effortlessly across the course with grace.

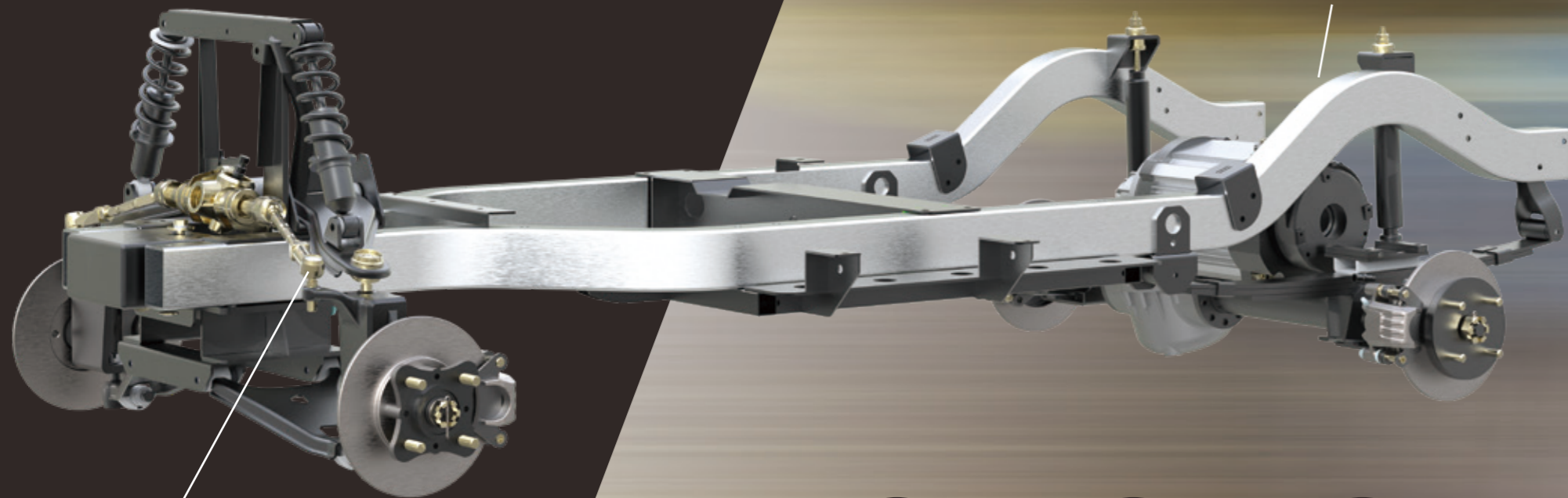

ALUMINUM FRAME

DOUBLE WISHBONE INDEPENDENT SUSPENSION



Double A-ARM



AC Induction Motor



Durability



PREMIUM LUXURY SEAT

TARA's luxury seats offer a perfect blend of comfort, protection, and style. Designed with soft-touch imitation leather that features an exotic carved pattern, these seats deliver a premium feel for all your cruising needs. Whether you're commuting or simply enjoying a leisurely drive, our luxury seats ensure you do so in ultimate comfort and elegance.

ALUMINUM CANOPY SUPPORTS

Make your golf cart the toughest one on the golf course, keep all rusts off your exposed canopy parts.

BUILT-IN DASH REFRIGERATOR

Perfect for keeping refreshments cool, making it the ideal addition for a day on the greens. Enjoy chilled beverages anytime during your game.



DESIGNED FOR GOLFING



ROADSTER 2

SIT BACK. YOU'RE IN A WORLD OF YOUR OWN.

The TARA has flowing contours that are crafted in your choice of premium materials, depending on how you wish to configure your golf cart or accentuate the interior. A wide array of add-on accessories available for both golfing and personal use.



Golf Bag Holder



Retractable Golf Bag Cover



Caddy Master Cooler



Ball Washer



Sand Bottle



Rake Holder
(Rake not included)

CUBOID SOUNDBAR



The premium cuboid soundbar boasts a sleek, compact design that includes additional speakers for enhanced audio quality. It connects wirelessly to the touchscreen and features adjustable lighting modes that synchronize with the music, creating a dynamic audio-visual experience.

FUN. FANCY. KEEP YOUR PARTY GOING



Apple CarPlay



Android Auto



TOUCHSCREEN WITH CARPLAY COMPATIBILITY

CarPlay compatibility for a more intuitive driving experience, seamless connectivity with your favorite apps.



ILLUMINATED SPEAKERS

Enhance your audio experience with the Illuminated Speakers, crafted to provide exceptional sound quality and dynamic ambient lighting for a visually stunning appeal.

LED LIGHTING

**BEAM AT THE DARKNESS !ECO-FRIENDLY. COST-EFFICIENT.
LONG LASTING. HASSLE-FREE.**

Our personal transportation vehicles come standard with LED lights, high beams, low beams, daytime running lights, turn signals, and brake lights for a brighter ride. Our lights are more powerful with less drain on your batteries, delivering 2-3 times wider field of vision than our competitors, so you can enjoy the ride worry-free, even after the sun goes down.



LITHIUM BATTERY

- ULTRA SAFE
- 8-YEAR WARRANTY
- MAINTENANCE FREE



Our lithium-ion battery packs are meticulously designed as a seamless drop-in replacement for lead-acid batteries. Enjoy the advantages of lithium-ion technology, such as reduced weight, faster charging, extended lifespan, maintenance-free operation, and lower electricity bills. Our battery features an integrated management system with an On/Off switch and a state-of-charge (SOC) gauge for enhanced control and monitoring.



MODEL: L48105

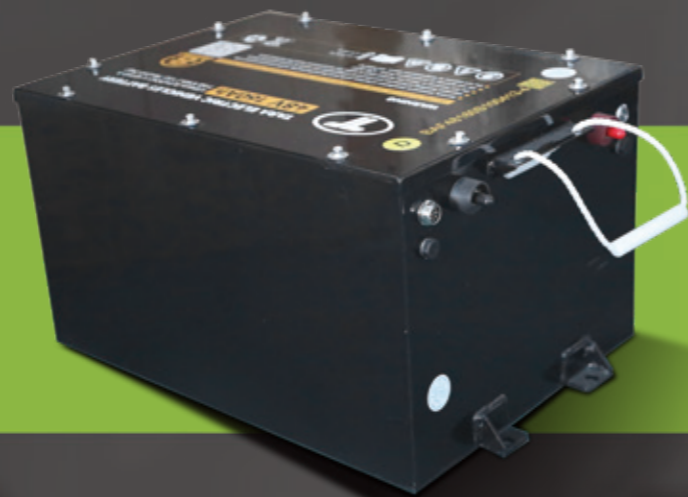

MODEL: L48160



25A Adaptive On-board Charger



Mobile & PC Live Monitor App

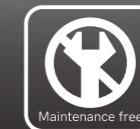

Maintenance free



Quick charging



Light weight



Safety

FEATURES

*PLEASE NOTE THAT, DUE TO VARIATIONS AMONGST PRINTINGS, ACTUAL COLORS MAY VARY SLIGHTLY FROM WHAT APPEARS ON THIS PAGE. CHECK WITH DEALER FOR ACTUALLY BRIGHTNESS/SATURATION OF A COLOR (CHECK THE PHYSICAL COLOR TEMPLATES POSSESSED BY DEALERSHIPS BEFORE YOU PLACE ORDERS). WE RESERVE THE RIGHTS TO MAKE CORRECTIONS AS WELL AS PRODUCT ALTERATIONS AND IMPROVEMENTS AT ANY TIME WITHOUT NOTICE



OVERHEAD STORAGE COMPARTMENT

Offers a convenient and accessible space for storing your essentials.



STORAGE COMPARTMENT WITH GOLF BALL HOLDER

Keeps you ready for golfing. Holds multiple golf balls.



CUP HOLDERS

Enhancing convenience by securely holding beverages, preventing spills as you navigate the course or cruise around your community.



ACCELERATOR / BRAKE PEDAL

Navigate with ease as our accelerator/brake pedal layout provides added legroom and a more intuitive driving experience.

PPG COLORS & SEAT COLORS



TR DIMENSIONS

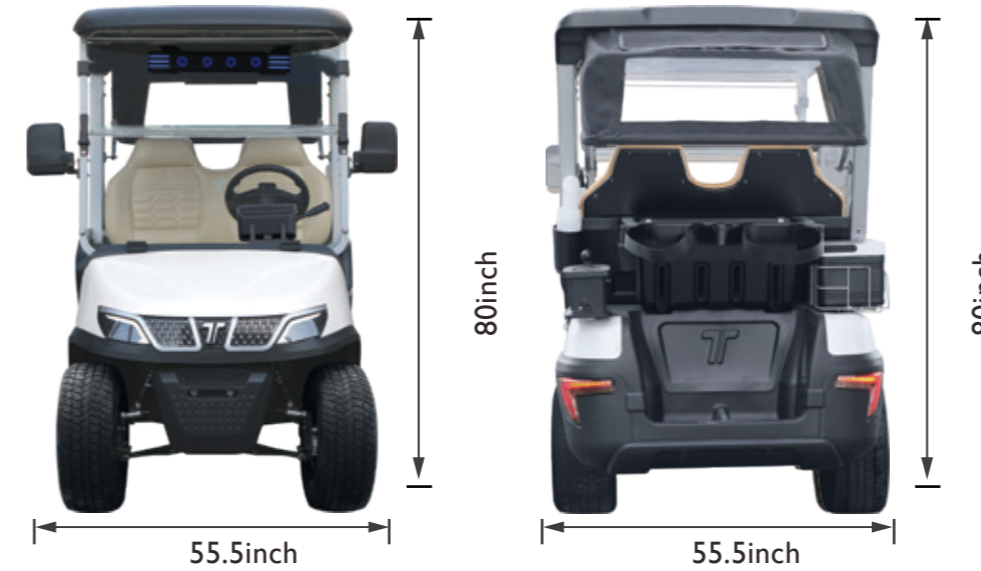

ROADSTER 2

Rated Passengers (person)	2
System Voltage (v)	48
Motor Power (kw)	6.3
Charging Time (H)	3-5
Dimension (inch)	99.6x55.5(rearview mirror)x80
Wheelbase (inch)	64.7
Wheel Tread (front/rear inch)	39.2/39.6
Maximum Speed (mph)	25
Braking Distance (feet)	≤9.8
Minimum Turning Radius (feet)	≤9.8
Maximum Gradability (full load)	25%
Curb Weight (lbs)	882
Maximum Gross Weight (lbs)	1212
Minimum Ground Clearance (inch)	6.1
Suspension System	Front: double wishbone independent suspension Rear: leaf spring suspension

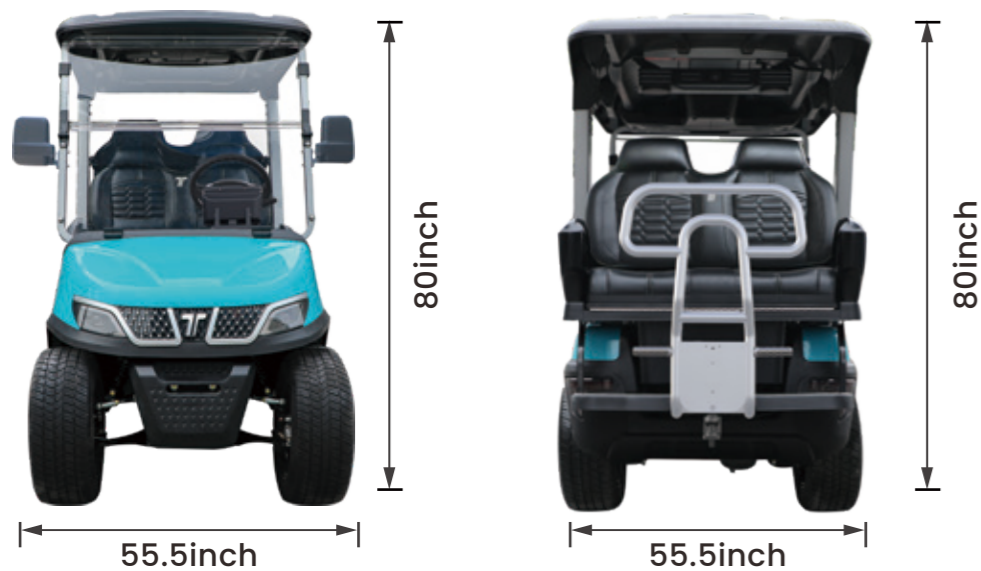

ROADSTER 2+2

Rated Passengers (person)	4
System Voltage (V)	48
Motor Power (kw)	6.3
Charging Time (H)	3-5
Dimension (inch)	117x55.5(rearview mirror)x80
Wheelbase (inch)	64.8
Wheel Tread (front/rear inch)	39.2/39.6
Maximum Speed (mph)	25
Braking Distance (feet)	≤13.1
Minimum Turning Radius (feet)	≤16.4
Maximum Gradability (full load)	25%
Curb Weight (lbs)	904
Maximum Gross Weight (lbs)	1565
Minimum Ground Clearance (inch)	7.1
Suspension System	Front: double wishbone independent suspension Rear: leaf spring suspension



EXPLORER 2+2

Rated Passengers (person)	4
System Voltage (V)	48
Motor Power (kw)	6.3
Charging Time (H)	3-5
Dimension (inch)	120.5x55.5(rearview mirror)x83
Wheelbase (inch)	64.8
Wheel Tread (front/rear inch)	39.3/39.7
Maximum Speed (mph)	25
Braking Distance (feet)	≤13.1
Minimum Turning Radius (feet)	≤16.4
Maximum Gradability (full load)	25%
Curb Weight (lbs)	1014
Maximum Gross Weight (lbs)	1676
Minimum Ground Clearance (inch)	7.9
Suspension System	Front: double wishbone independent suspension Rear: leaf spring suspension

